

Molecular Recognition of Long Dicarboxylate/Dicarboxylic Species via Supramolecular/Coordinative Interactions with Ditopic Receptors. Crystal Structure of $\{[\text{Cu}_2\text{L}(\text{H}_2\text{O})_2]\text{pimelate}\}(\text{ClO}_4)_2$

Carla Bazzicalupi,[†] Andrea Bencini,^{*,†} Antonio Bianchi,^{*,†} Vieri Fusi,[‡] Enrique Garcia-España,^{*,§} Claudia Giorgi,[†] José M. Llinares,[§] José Antonio Ramirez,[§] and Barbara Valtancoli[†]

Department of Chemistry, University of Florence, Via Maragliano 75/77, 50144 Florence, Italy, Institute of Chemical Sciences, University of Urbino, Via Stazione 4, 61029 Urbino, Italy, and Department of Inorganic Chemistry, University of Valencia, C/ Dr. Moliner 50, 46100 Burjassot, Valencia, Spain

Received October 15, 1998

Molecular recognition of anions by synthetic receptors has received increasing attention in the past few years.¹ The main strategy for achieving strong and selective anion binding in solution is based on the use of positively charged macrocyclic receptors, mostly of polyammonium type. Another possibility in the synthesis of anion receptors is the incorporation of metal centers with which the anion may form coordinative bonds. From these points of view, polyazacycloalkanes offer the double challenge of forming highly charged polyammonium cations and polynuclear metal complexes for the recognition of polyfunctional anions.^{1c} In particular, in the case of ditopic polyazamacrocycles there are three possible modes for the recognition of difunctional anions (Figure 1): (i) binding to two polyammonium sites, (ii) binding to two metal sites, and (iii) binding to one metal site and one polyammonium site. To give rise to all three binding modes a ligand must meet several requisites. A ditopic nature is the first requisite, but it is not enough. The ligand must form highly charged polyammonium sites to achieve a tight association with difunctional anions via binding mode i. This can be accomplished by inserting many amine groups in the binding moieties of the ligand, but a high number of donor atoms tends to fulfill the coordination environments of the metal ions, impeding binding mode ii. Furthermore the two coordination moieties must behave as much as possible as independent binding sites in order to allow the formation of symmetrically protonated species, stable dinuclear complexes, and highly protonated mononuclear complexes in which many protons are bound to the opposite site of the metal ion.

Taking into account these considerations, we have designed and synthesized the ditopic cyclophane ligand **L** composed of two pentaamine moieties, each one containing two piperazine rings, linked together by benzene spacers.² Previous studies

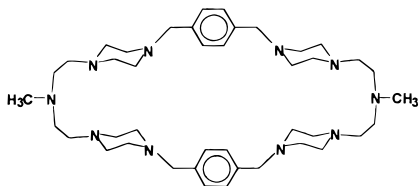

demonstrated that such pentaamine moieties produce highly protonated species in aqueous solution and, due to the presence of piperazine components, form stable Cu^{II} complexes in which the metal ions are characterized by low coordination numbers.³ Solution studies on ligand protonation and Cu^{II} complexation demonstrate that **L** contains two binding subunits actually behaving as almost independent sites. Furthermore, the crystal

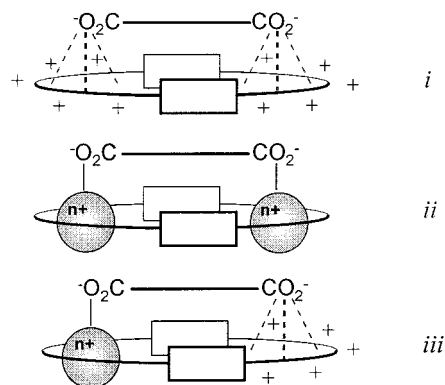

Figure 1. Supramolecular and coordinative binding modes of dicarboxylate anions.

structure of the $\{[\text{Cu}_2\text{L}(\text{H}_2\text{O})_2]\text{pimelate}\}(\text{ClO}_4)_2$ complex⁴ confirms that the ligand involves only three out of five nitrogen atoms of each moiety in the binding of the metal ions inducing the formation of cascade complexes with difunctional anions.

The structural evidence for binding mode ii up to now reported for difunctional anions involve anion coordination by binuclear Cu^{II} or Zn^{II} complexes, containing two metal centers at a short distance from each other ($<6 \text{ \AA}$).⁷ In the present case, as displayed by the crystal structure of $\{[\text{Cu}_2\text{L}(\text{H}_2\text{O})_2]\text{pimelate}\}(\text{ClO}_4)_2$, recognition of a long difunctional anion is achieved by bridging coordination to the metal centers held by **L** at a very long distance (10.956(4) \AA).

- (1) (a) *Supramolecular Chemistry of Anions*; Bianchi, A., Bowman-James, K., Garcia-España, E., Eds.; Wiley-VCH: New York, 1997. (b) Atwood, J. L.; Holman, K. T.; Steed, J. W. *Chem. Commun.* **1996**, 1401. (c) Lehn, J.-M. *Supramolecular Chemistry, Concepts and Perspectives*; VCH: Weinheim, 1995. (d) Beer, P. D.; Wheeler, J. W.; Moore, C. In *Supramolecular Chemistry*; Balzani, V., De Cola, L., Eds.; Kluwer Academic Publishers: Netherlands, 1992. (e) Katz, H. E. In *Inclusion Compounds*; Atwood, J. L., Davies, J. E. D., MacNicol, D. D., Eds.; Oxford University Press: Oxford, 1991.
- (2) Details regarding the synthesis of **L** and of $\{[\text{Cu}_2\text{L}(\text{H}_2\text{O})_2]\text{pimelate}\}(\text{ClO}_4)_2$ are reported as Supporting Information.
- (3) Bazzicalupi, C.; Bencini, A.; Bianchi, A.; Fusi, V.; Giorgi, C.; Paoletti, P.; Valtancoli, B. *J. Chem. Soc., Dalton Trans.* **1997**, 3535–3541.
- (4) Crystal structure analysis for $\{[\text{Cu}_2\text{L}(\text{H}_2\text{O})_2]\text{pimelate}\}(\text{ClO}_4)_2$: $\text{C}_{49}\text{H}_{84}\text{Cl}_2\text{Cu}_2\text{N}_{10}\text{O}_{14}$, MW = 1235.24, prismatic blue crystals (approximate dimensions 0.3 mm \times 0.3 mm \times 0.4 mm), orthorhombic space group *Ccmm*, with $a = 15.177(4) \text{ \AA}$, $b = 28.170(8) \text{ \AA}$, $c = 17.210(6) \text{ \AA}$, $V = 7358 \text{ \AA}^3$, $Z = 4$, $D_c = 1.115 \text{ Mg/m}^3$, $F(000) = 2608$, $\mu(\text{Mo K}\alpha) = 0.706 \text{ mm}^{-1}$. A total of 3411 reflections ($2.5^\circ < \theta < 25^\circ$, scan mode θ - 2θ , T 298 K) were measured on an Enraf-Nonius CAD4 X-ray diffractometer; Mo $\text{K}\alpha$ radiation ($\lambda = 0.71069 \text{ \AA}$). Lorentz and polarization effects were applied. The structure was solved by the heavy-atom technique and refined by a full-matrix least-squares procedure against F^2 with the SHELXL-93 program.⁵ An absorption correction was applied once the structure was solved (DIFABS).⁶ Final R indices [205 refined parameters, reflections with $I > 2\sigma(I)$]: $R1 = 0.1138$, $wR2 = 0.2863$. R indices (all data): $R1 = 0.2597$, $wR2 = 0.4350$.
- (5) Sheldrick, G. M. *SHELXL93. Program for the Refinement of Crystal Structures*; University of Göttingen: Göttingen, Germany, 1993.
- (6) Walker, N.; Stuart, D. D. *Acta Crystallogr., Sect. A* **1983**, 39, 158.

[†] University of Florence.

[‡] University of Urbino.

[§] University of Valencia.

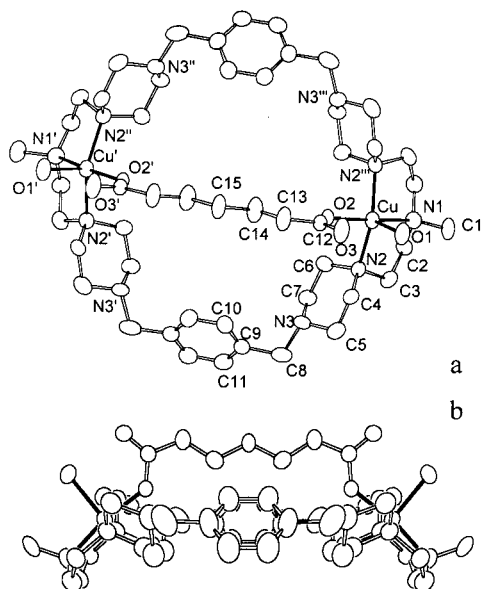

Figure 2. ORTEP⁸ drawings of the $\{[Cu_2L(H_2O)_2]pimelate\}^{2+}$ complex (thermal ellipsoids at 30% probability): (a) top view, (b) lateral view. Selected bond lengths (Å) and angles (deg): Cu–O2 1.940(10), Cu–N1 2.017(14), Cu–N2 2.063(10), Cu–O1 2.189(11), O2–Cu–N1 169.8(6), O2–Cu–N2 90.8(3), N1–Cu–N2 86.7(3), O2–Cu–O1 93.0(4), N1–Cu–O1 97.2(6), N2–Cu–O1 104.3(3).

The molecular structure of $\{[Cu_2L(H_2O)_2]pimelate\}(ClO_4)_2$ consists of $\{[Cu_2L(H_2O)_2]pimelate\}^{2+}$ complex cations (Figure 2) and perchlorate anions. The complex cation possesses two crystallographic planes, perpendicular to each other, one containing the copper atoms, N1, N1', O1, and all the atoms belonging to the pimelate anion, the other one bisecting the C10–C10' bond and passing through the C15 carbon atom of the pimelate chain. Each metal ion, Cu–Cu distance 10.959(4) Å, is coordinated by three nitrogens of the ligand (N1, N2, and N2'''), a water molecule (O1), and a carboxylic oxygen (O2). The coordination environment for the two metal ions is square pyramidal, with the basal plane defined by N1, N2, N2''', and O2 (deviation from the mean plane ranging from 0.110(9) to 0.32(1) Å) and the apical position occupied by the water molecule. The copper atom is displaced from this plane 0.391(2) Å toward the apical position. The ligand adopts an almost circular conformation (approximate dimensions 10 Å × 11 Å), with the piperazine rings in a chair conformation and the aromatic rings almost perpendicular to each other (dihedral angle: 91.3(5)°). The dicarboxylate anion is inserted between the two copper cations over the macrocyclic plane. A strong H-bond interaction is likely present between O3 of the pimelate and the water molecule (O1···O3 2.62(2) Å).

As expected, the ditopic cyclophane **L** gives rise to strong association with pimelate and its protonated forms in aqueous solution, both in the absence and in the presence of Cu^{II}, according to the three binding modes i–iii.

In the absence of metal ion, association between protonated forms of **L** and pimelate (pim^{2-}), hydrogen pimelate ($Hpim^-$), and pimelic acid (H_2pim) is observed from acidic to alkaline pH, the association constants being $\log K = 3.15(7)$ – $3.91(5)$ for $H_nL^{n+} + pim^{2-} = [H_nLpim]^{(n-2)+}$ ($n = 2$ – 6), $\log K = 3.85(4)$ – $6.27(3)$ for $LH_n^{n+} + Hpim^- = [H_nLHpim]^{(n-1)+}$ ($n = 6$ – 8), and $\log K = 4.33(6)$ for $LH_8^{8+} + H_2pim = [H_8LH_2pim]^{8+}$.⁹ Ligand protonation occurs in turn on the two separated polyamine

moieties, allowing substrate coordination of the i mode, similarly to the cases described by Hosseini and Lehn in the historic work¹¹ on the recognition of dicarboxylate anion by ditopic polyammonium receptors. Over 80% of coordinated substrate is present in the pH range 2–4 for solutions containing equimolar (1×10^{-3} mol dm⁻³) concentrations of substrate and receptor; at higher pH, the percentage of substrate bound to **L** decreases (50% at pH 8), vanishing at pH > 10 (a distribution diagram is reported as Supporting Information).

In presence of Cu^{II}, **L** forms both mono- and dinuclear complexes, the second ones being favored by 2:1 metal to ligand molar ratios. $[CuL]^{2+}$ displays a marked tendency to bind H⁺ ions forming highly protonated species (up to $[CuH_5L]^{7+}$) devising the conditions for anion binding mode iii. Both mono- and dinuclear species form stable cascade complexes with pimelate. The formation of metal complexes maintains a larger proportion of substrate in coordinated form with respect to the metal-free system. Actually the percentage of free substrate keeps almost constant, at about 20%, up to pH 8 when $[L] = [pim] = 0.5$ – $[Cu^{II}] = 1 \times 10^{-3}$ mol dm⁻³.

It is worth noting that recognition of the different substrate forms (H_2pim , $Hpim^-$, pim^{2-}) occurs, in successive pH ranges, by means of the different receptor species produced by the system. For instance, for a 1:2:1 L:Cu^{II}:pim ($[L] = 1 \times 10^{-3}$ mol dm⁻³) system (the relevant distribution diagram is reported as Supporting Information), the substrate coordination features a shift from the supramolecular type of mode i, occurring at pH < 4, where H_2pim is recognized by the most charged form of **L** ($\log K = 4.33$ – 6) for $LH_8^{8+} + H_2pim = [H_8LH_2pim]^{8+}$, to the coordinative type of mode ii above pH 6 where pim^{2-} interacts with the binuclear complexes ($\log K = 3.43(6)$, $4.35(2)$, $4.43(2)$ for $[Cu_2H_nL]^{(4+n)+} + pim^{2-} = [Cu_2H_nLpim]^{(2+n)+}$, $n = 0$ – 2), through the formation of supramolecular/coordinative adducts (mode iii) formed in the intermediate pH range 4–6 where $Hpim^-$ is the main species recognized by the mononuclear complex with the highest protonation degree ($\log K = 4.85(4)$ for $[CuH_5L]^{7+} + Hpim^- = [CuH_5LHpim]^{6+}$).⁹

Above pH 8 the substrate is released by the complex due to the formation of the dihydroxylated dicopper complex $[Cu_2L(OH)_2]^{2+}$ ($\log K = 13.52(4)$ for $[Cu_2L]^{4+} + 2OH^- = [Cu_2L(OH)_2]^{2+}$) which is unable to bind the dicarboxylate anion.

The cyclophane **L** and its copper(II) complexes are thereby successful hosting species for the recognition of long difunctional substrates such as pimelate, hydrogen pimelate, and pimelic acid. In particular, strong binding of a dicarboxylic acid by a polyammonium receptor ($\log K = 4.33(6)$ for $LH_8^{8+} + H_2pim = [H_8LH_2pim]^{8+}$)⁹ is a striking result, especially in water.

Supporting Information Available: Details regarding the synthesis of **L** and $\{[Cu_2L(H_2O)_2]pimelate\}(ClO_4)_2$ species distribution diagrams, and complete tables of crystallographic details, atomic positions and displacement parameters, bond lengths and angles, and weighted least-squares planes through selected atoms. This material is available free of charge via the Internet at <http://pubs.acs.org>.

IC9812151

(7) Search at the Cambridge Crystallographic Data Centre according to Allen et al.: Allen, F. A.; Bellard, S.; Brice, M. D.; Cartwright, B. A.; Doubleday, A.; Higgs, H.; Hummelink, T.; Hummelink-Peters, B. G.; Kennard, O.; Motherwell, W. D. S.; Rodgers, J. R.; Watson, D. G. *Acta Crystallogr., Sect. B* **1979**, 35, 2331.

(8) Johnson, C. K. ORTEPII. Report-5138; Oak Ridge National Laboratory: Oak Ridge, TN, 1973.

(9) All equilibrium constants were determined by means of potentiometric titrations (0.15 mol dm⁻³ NaCl, 298.1 ± 0.1 K). Potentiometric data were processed by means of the computer program HYPERQUAD.¹⁰ The number of protons bound to **L** in the adducts had been determined by ¹H and ¹³C NMR measurements. The equilibrium constants for the addition of $Hpim^-$ and H_2pim to Cu^{II} complexes were calculated assuming that the protonation state of the interacting species is maintained in the adducts, as observed in the absence of metal.

(10) Gans, P.; Sabatini A.; Vacca, A. *Talanta* **1996**, 43, 1739.

(11) Hosseini, M. W.; Lehn, J.-M. *J. Am. Chem. Soc.* **1982**, 104, 3525.